

RACCORDS RAPIDES A CAMES LAITON (2261-2268)

Raccords rapides à cames laiton pour fluides courants compatibles du groupe 2.
Conforme à la norme MIL-C-27487 et A-A 59326.
L'étanchéité est assurée par un joint NBR sur le coupleur.



Dimensions : DN15 à DN100 (1/2" à 4")
Raccordement : Femelle, Mâle BSP ou cannelé
Température Mini : -10°C
Température Maxi : +80°C
Pression Maxi : 16 Bars
Caractéristiques : Raccords en laiton
Joint NBR
Cames laiton
Conforme à la norme MIL-C-27487 et A-A 59326

Matière : Laiton

RACCORDS RAPIDES A CAMES LAITON (2261-2268)

CARACTERISTIQUES :

- Raccords en laiton
- Joint NBR (uniquement sur les coupleurs)
- Conforme à la norme MIL-C-27487 et A-A 59326

UTILISATION :

- Fluides courants compatibles du groupe 2
- Température mini et maxi admissible Ts : - 10°C à + 80°C avec joint NBR
- Pression maxi admissible Ps : Suivant tableau ci dessous

DN	1/2"	3/4"	1"	1"1/4	1"1/2	2"	2"1/2	3"	4"
Ps (Bar)	11	16	16	16	16	16	11	9	7

GAMME :

- Adaptateur femelle type A **Ref.2261** du DN 1/2" au DN 4"
- Coupleur mâle type B **Ref.2262** du DN 1/2" au DN 4"
- Coupleur cannelé type C **Ref.2263** du DN 1/2" au DN 4"
- Coupleur femelle type D **Ref.2264** du DN 1/2" au DN 4"
- Adaptateur cannelé type E **Ref.2265** du DN 1/2" au DN 4"
- Adaptateur mâle type F **Ref.2266** du DN 1/2" au DN 4"
- Bouchon coupleur type DC **Ref.2267** du DN 1/2" au DN 4"
- Bouchon adaptateur type DP **Ref.2268** du DN 1/2" au DN 4"
- **Sur demande : joints EPDM ou FKM**

TEMPERATURES ET REFERENCES JOINTS NBR, EPDM :

JOINT	TEMPERATURE	1/2"	3/4"	1"	1"1/4	1"1/2	2"	2"1/2	3"	4"
NBR	-10°C à +80°C	9830860	9830861	9830862	9830863	9830864	9830865	9830866	9830867	9830868
EPDM	-10°C à +130°C	9830850	9830851	9830852	9830853	9830854	9830855	9830856	9830857	9830858

RACCORDS RAPIDES A CAMES LAITON (2261-2268)

NOMENCLATURE:

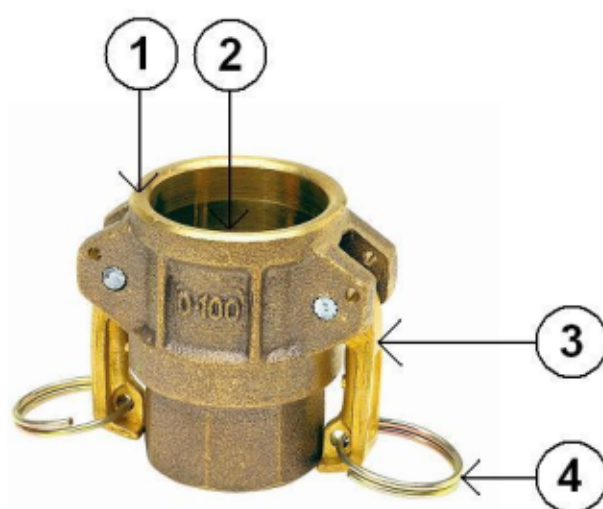

Repère	Désignation	Matériaux
1	Corps	Laiton
2	Joint	NBR
3	Cames	Laiton ou Inox AISI 301
4	Bagues	Laiton

RACCORDS RAPIDES A CAMES LAITON (2261-2268)

DIMENSIONS (en mm) :

- Adaptateur femelle type A Ref.2261

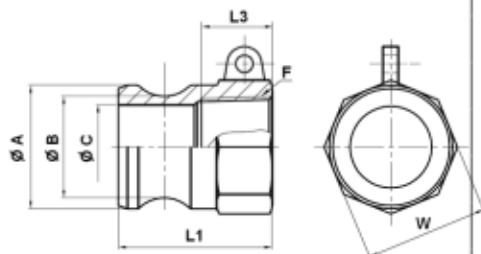

Ref.	DN	1/2"	3/4"	1"	1"1/4	1"1/2	2"	2"1/2	3"	4"
2261	F	1/2"	3/4"	1"	1"1/4	1"1/2	2"	2"1/2	3"	4"
	Ø A	24	32.4	36.7	45.5	53.5	63	75.8	91.5	119.5
	Ø B	18.2	26.2	29	35.2	43.1	52.5	64.6	81	106
	Ø C	14.5	22.7	25.4	31	38.5	47.5	59	75	102.4
	L1	36.5	36.5	44.5	51	54	60.5	66	67	72
	L3	14	16	20	21	23	26	29	30	33
	W sur plat	26.5	32.5	37.5	47	54.5	65	80	94	120
	Poids (Kg)	0.08	0.11	0.15	0.21	0.3	0.42	0.81	0.77	1.29

- Coupleur mâle type B Ref.2262

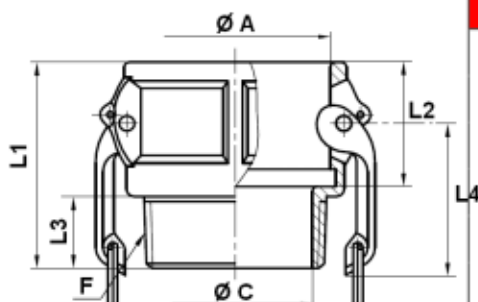

Ref.	DN	1/2"	3/4"	1"	1"1/4	1"1/2	2"	2"1/2	3"	4"
2262	F	1/2"	3/4"	1"	1"1/4	1"1/2	2"	2"1/2	3"	4"
	Ø A	24.6	32.4	37.3	46	54	63.8	76.5	92.2	120.3
	Ø C	12.8	19.5	25.4	34	40	50.5	63.5	76	100
	L1	44	45	54	61	63	83	82.5	84	90
	L2	27	29	36	42	42	47.5	50	51	52
	L3	16	15	18	20	20.5	29.5	30	31	36
	L4	34	34	42	59	59	59	59	70	70
	Poids (Kg)	0.18	0.21	0.33	0.53	0.56	0.68	1.1	1.35	2.19

- Coupleur cannelé type C Ref.2263

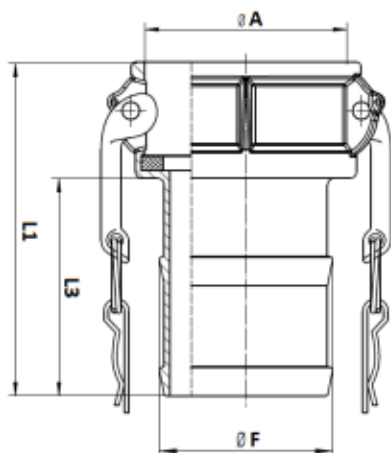

Ref.	DN	1/2"	3/4"	1"	1"1/4	1"1/2	2"	2"1/2	3"	4"
2263	Ø F	15	21	27.3	34	40.5	52.5	66	79	104
	Ø A	24.5	32.4	37.3	46	54	63.8	76.5	92.2	120.3
	L1	61.5	82	93	98	103	116	150.3	153	159
	L3	33.5	52	57	57	61	58	95.5	100	103
	Poids (Kg)	0.17	0.24	0.37	0.56	0.61	0.78	1.22	1.48	2.95

RACCORDS RAPIDES A CAMES LAITON (2261-2268)

DIMENSIONS (en mm) :

- Coupleur femelle type D Ref.2264

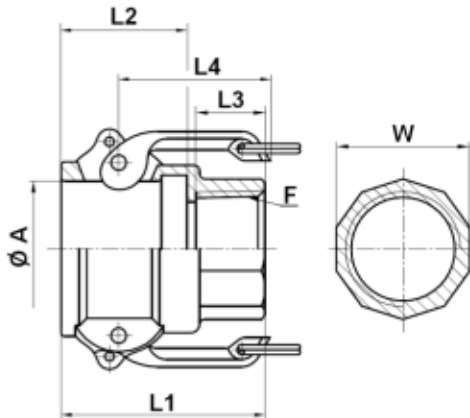

Ref.	DN	1/2"	3/4"	1"	1"1/4	1"1/2	2"	2"1/2	3"	4"
2264	F	1/2"	3/4"	1"	1"1/4	1"1/2	2"	2"1/2	3"	4"
	Ø A	24.3	32.4	37.3	46	54	63.8	76.5	92.2	120.3
	L1	43	46	54	60	62.5	72	82.5	82.5	90
	L2	27	29	36	42	42	47.5	50	51	52
	L3	15	15	18	20	21	24.5	30	30.5	35.5
	L4	34	34	42	59	59	59	59	70	70
	W sur plat	26	30	37	45	54	64	79	93.5	120
	Poids (Kg)	0.09	0.23	0.34	0.56	0.67	0.74	0.99	1.39	2.42

- Adaptateur cannelé type E Ref.2265

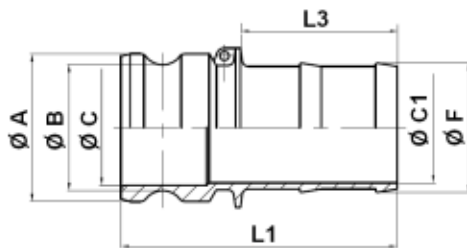

Ref.	DN	1/2"	3/4"	1"	1"1/4	1"1/2	2"	2"1/2	3"	4"
2265	Ø F	15.1	21.5	27.3	34	40.4	53	66.7	79.3	104.7
	Ø A	24	32.4	36.7	45.5	53.5	63	75.8	91.5	119.5
	Ø B	18.2	26.2	29	35.2	43.1	52.5	64.6	81	106
	Ø C	14.5	22.7	25.4	31	38.5	47.5	59	75	102.4
	Ø C1	8.5	15	21.4	27.3	33.7	46	58.5	69.5	94
	L1	70	86	101	106	112	128	138	160	163
	L3	44	50	55	56	58	67	78	99	108
	Poids (Kg)	0.11	0.18	0.29	0.35	0.47	0.71	1.14	1.37	2.45

- Adaptateur mâle type F Ref.2266

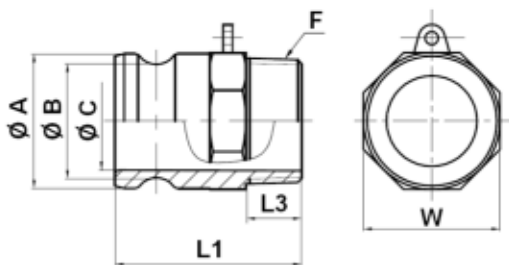

Ref.	DN	1/2"	3/4"	1"	1"1/4	1"1/2	2"	2"1/2	3"	4"
2266	F	1/2"	3/4"	1"	1"1/4	1"1/2	2"	2"1/2	3"	4"
	Ø A	24	32.4	36.7	45.5	53.5	63	75.8	91.5	119.5
	Ø B	18.2	26.2	29	35.2	43.1	52.5	64.6	81	106
	Ø C	14.5	22.7	25.4	31	38.5	47.5	59	75.3	102.4
	L1	51.4	51.5	62	70	73.5	82.5	94	97	110
	L3	14	18	19	21	18	20	28	29	36
	W sur plat	25.4	32.5	38	46	54	64	78	93	120
	Poids (Kg)	0.09	0.14	0.2	0.29	0.36	0.57	0.9	1.21	1.94